

**GERMAN
PRECISION**

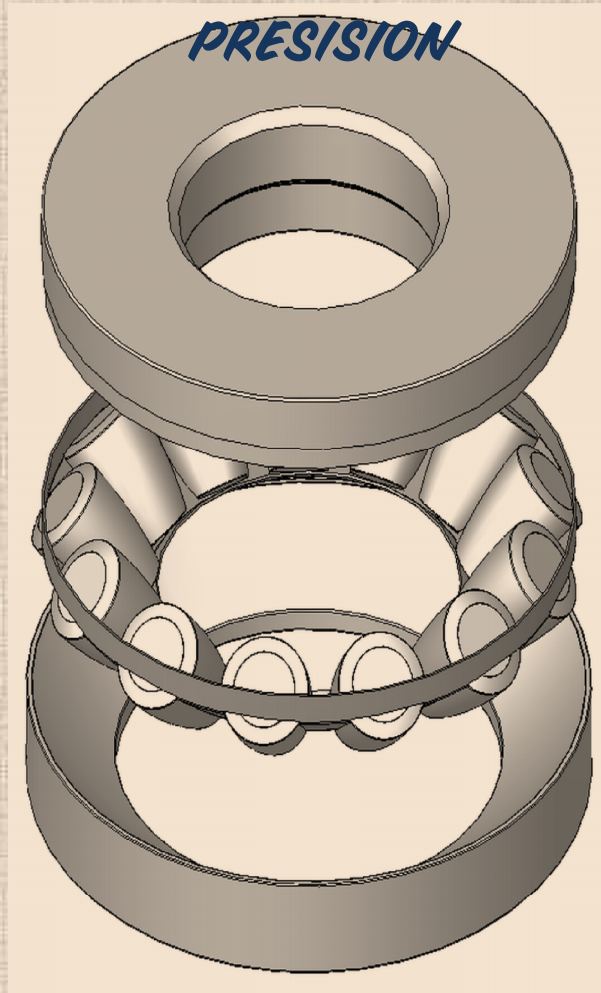

**THRUST SPHERICAL
ROLLER BEARING
PRECISION GERMAN**

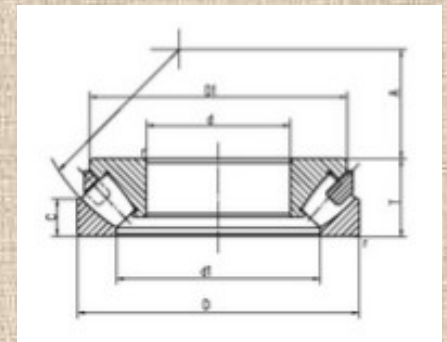

WWW.SMBEARING-EU.DE



WWW.SMBEARING-EU.DE

A spherical roller thrust bearing

Bearing number	Principal dimensions mm				Weight kg
	d	D	B	r smin	
29338	190	320	78	1100	23.300
29438		380	115	850	63.100
29340	200	340	85	1000	29.000
29440		400	122	800	69.000
29344	220	360	85	980	31.600
29444		420	122	750	74.00
29348	240	380	85	910	33.400
29448		440	122	700	83.000
29352	260	420	95	830	46.900
29452		480	132	660	105.00
29356	280	440	95	780	49.500
29456		520	145	620	127.000
29360	300	480	109	730	68.700
29460		540	145	580	133.000
29364	320	500	109	690	72.100
29464		580	155	540	164.000
29468	340	620	170	700	207.000
29376	380	561	132	650	150.000
29280	400	540	85	700	60.000
29380		620	132	620	146.00
29384	420	650	140	600	168.00
29488	440	780	206	540	399.000
29292	460	620	95	580	81.00

Bearing number	Principal dimensions mm				Weight kg
	d	D	B	r smin	
29412	60	130	42	2600	2.650
29413	65	140	45	2400	3.300
29414	70	150	48	2300	4.000
29415	75	160	51	2100	4.870
29416	80	170	54	2000	5.840
29417	85	180	58	1800	6.950
29418	90	190	60	1800	8.080
29320	100	170	42	2100	3.650
29420		210	67	1600	11.000
29322	110	190	48	1900	5.480
29422		230	73	1400	14.500
29324	120	210	54	1700	7.580
29424		250	78	1300	18.100
29326	130	225	58	1600	9.300
29426		270	85	1200	22.500
29328	140	240	60	1500	11.00
29428		280	85	1200	24.200
29330	150	250	60	1400	11.500
29430		300	90	1100	29.400
29332	160	270	67	1300	15.200
29432		320	95	1000	37.300
29334	170	280	67	1300	16.000
29434		340	103	950	43.700
29336	180	300	73	1200	20.300
29436		360	109	900	52.000

Is. rolling-element bearing of thrust type that permits rotation with low friction, and permits angular misalignment. The bearing is designed to take radial loads, and heavy axial loads in one direction. Typically these bearings support a rotating shaft in the bore of a shaft washer that may be misaligned in respect to the housing washer. The misalignment is possible due to the spherical internal shape of the housing washer.



WWW.SMBEARING-EU.DE